

A cleaner, safer,
faster alternative to Pour Strips

CI/SfB	(29)	Et6	
July 2018 (Version 2)			



Ancon[®]

Lockable Dowels

for Temporary Movement Joints
in Post-Tensioned Concrete

Ancon Lockable Dowels

Contents

Advantages and Applications	2-3
Range of Lockable Dowels	4-5
Performance Data	6
Edge Distance and Spacings	7
Reinforcement Details	8
Dimensions	9
Installation	10
Projects	11
Other Ancon Products	11



Ancon Lockable Dowel

European Patent No. 2191078
US Patent No. 8209933
Singapore Patent No. 159760
South Africa Patent No. 2010/01651
Australian Patent No. 2008294503
New Zealand Patent No. 583887



Lockable Dowels

Lockable Dowels have been designed by Ancon for use at temporary movement joints, most commonly found in post-tensioned concrete frames.

These dowels allow initial shrinkage of the concrete to take place and are then locked in position with a mechanical plate and a controlled amount of epoxy resin. The locked dowels continue to transfer shear, but prevent further movement taking place.

Advantages

The use of Lockable Dowels can save a significant amount of time and materials over other construction methods. Traditionally, concrete shrinkage has been accommodated by leaving gaps in the slab called 'pour strips' or 'closure strips'. These strips are filled once movement has stabilised, however until they are filled the slabs must be propped, restricting site access and delaying site progress. Gaps in the slab also create a trip hazard for site workers, use additional formwork and can leave the soffit face marked.



Pour Strips restrict site access, cause a trip hazard and delay progress on site

Lockable Dowels improve site access, minimise formwork requirements and accelerate the rate of construction. With a Lockable Dowel, there is less requirement for the slabs to be propped or a support corbel to be constructed, as shear load is transferred by the dowel. The time saved by early removal of slab props can be significant.

A Lockable Dowel also provides many advantages over the site-assembled arrangement of carbon steel reinforcing bar, galvanised or plastic ducting, vent tubes and a non-specific grout, which is sometimes used by contractors.

In addition, engineers have found the Ancon Lockable Dowel to be the preferred design solution for pin-ended joints. Although it is customary for practical reasons to use U-bars or other rebar continuity systems at these connections, these options do not truly act as hinges and so rotation of the slab under load can induce cracking at the wall-to-slab interface with potential integrity issues.



The Lockable Dowel eliminates the need for Pour Strips, accelerating the speed of construction and improving site safety

The Lockable Dowel is closer to a true pin-ended joint and, being manufactured from stainless steel, provides additional corrosion protection over systems using carbon steel reinforcement.

The design capacities shown on page 6 are backed by independent test data and the unique void former allows inspection of the dowel before the joint is locked.

Standard Ancon systems are available for use at slab joints and retaining / core walls.

- ✓ Eliminate pour strips
- ✓ Reduce propping times
- ✓ Reduce formwork
- ✓ Improve site access
- ✓ Faster, safer construction
- ✓ Proven performance

Applications

In most cases, Ancon Lockable Dowels can be used to replace pour strips at temporary movement joints in post-tensioned concrete frames. Standard Ancon systems are available for use at slab joints and retaining / core walls.

Slab-to-Slab

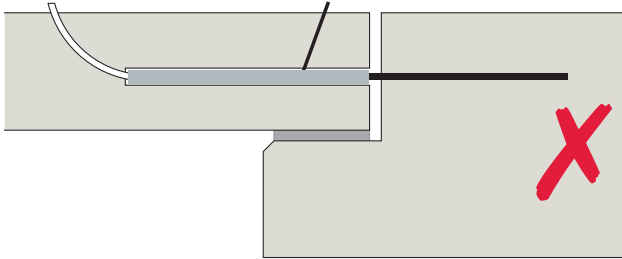

Various site-assembled components

Unreliable performance, additional construction materials used and support corbel or prop required

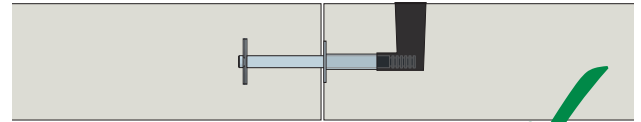

Ancon Lockable Dowel

**Proven performance
Minimal material usage**

Slab-to-Slab

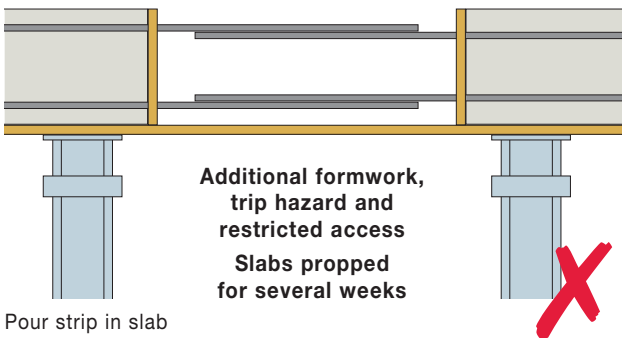

Pour strip in slab

**Additional formwork,
trip hazard and
restricted access
Slabs propped
for several weeks**

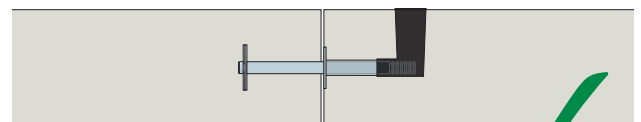

Ancon Lockable Dowel

**Minimal formwork
Improved site access
Reduced propping time**

Slab-to-Wall

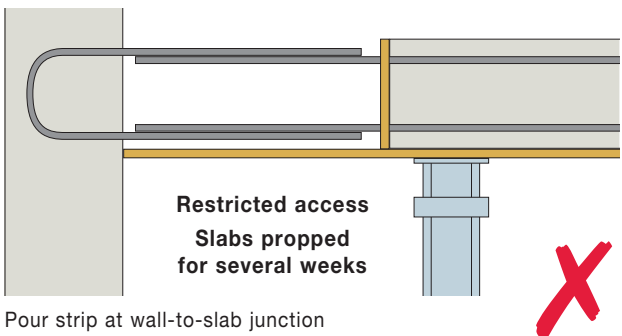

Pour strip at wall-to-slab junction

**Restricted access
Slabs propped
for several weeks**

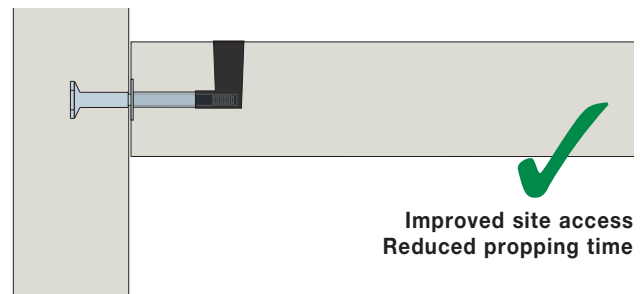

Ancon Lockable Dowel

**Improved site access
Reduced propping time**

Hybrid Construction

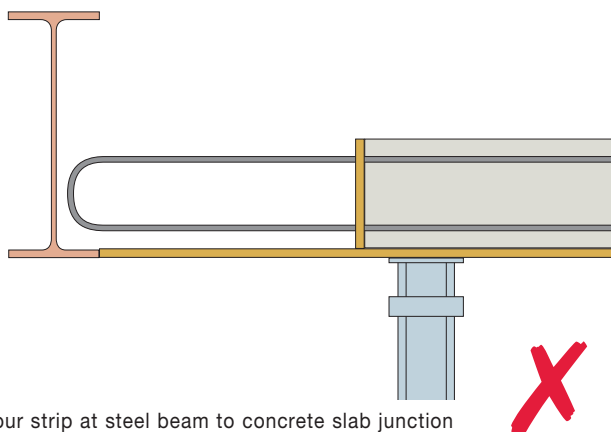

Pour strip at steel beam to concrete slab junction

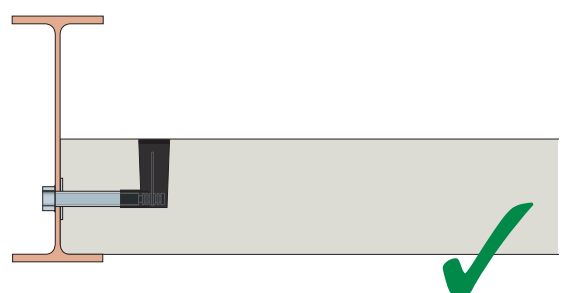

Ancon Lockable Dowel, in conjunction with Ancon Weldable Coupler. Contact Ancon with details of your project requirements.

Ancon Lockable Dowels

Range of Lockable Dowels

A Lockable Dowel allows initial shrinkage of the concrete to take place and then, after a pre-determined time period (generally 3-4 weeks), is locked in position with a mechanical plate and a controlled amount of epoxy resin. The range comprises three products; ESDQ-L20, HLDQ-L30 and ESDQ-L20W.

Slab-to-Slab Lockable Dowels

ESDQ-L20

The dowel component is manufactured from 30mm diameter stainless steel; one end features two fixed overlapping anchor discs and the other has a series of grooves to accept the Locking Plate. The cylindrical sleeve which accepts the dowel component is contained within a box-section to allow lateral, longitudinal and some rotational movement. The epoxy resin is poured into the L-shaped void former. This product has a design capacity of up to 71kN. See pages 6-9 for full technical details.

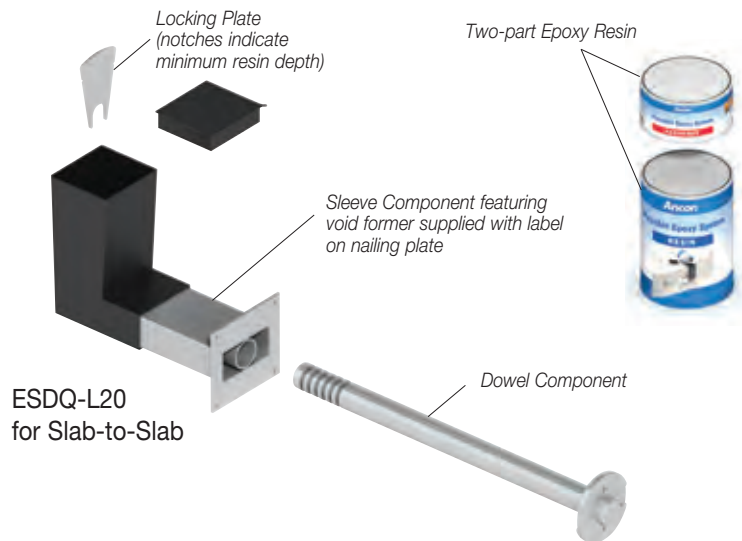

Reinforcement being located around ESDQ-L20 Sleeves

HLDQ-L30

The HLDQ-L30 is a high load Lockable Dowel with a design capacity of up to 136kN. See pages 6-9 for full technical details.

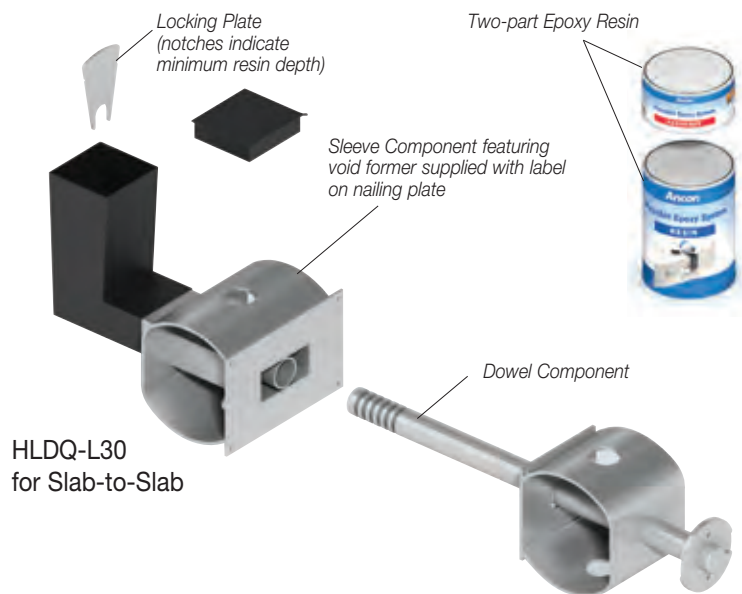

HLDQ-L30 Sleeve nailed to formwork

Example Specification Clause

Delete/Amend blue text as appropriate

<Ancon ESDQ-L20 or Ancon HLDQ-L30> lockable shear load connector comprising dowel, sleeve and locking components to be installed at the temporary movement joint between two slabs. Product to be positioned at <insert centres>mm horizontal centres at <the centre line of the slab or XXXmm from the top of the slab>. The dowel is to be locked in position after <insert time period> using the locking plate and resin supplied. System should be installed in accordance with Ancon's instructions and engineer's drawings.

Slab-to-Wall Lockable Dowel ESDQ-L20W

The dowel component is manufactured from 30mm diameter stainless steel, but is shorter than the ESDQ-L20 dowel. One end of the dowel is designed to fix into the stainless steel Ancon SKS24 Threaded Anchor cast into the face of the concrete and the other end features a series of grooves to accept the Locking Plate. The sleeve component is the same as used in the ESDQ-L20. See pages 6-9 for full technical details.



Sleeve pushed over dowel component at core wall

Example Specification Clause

Delete/Amend blue text as appropriate

Ancon ESDQ-L20W lockable shear load connector comprising dowel, sleeve, threaded anchor and locking components to be installed at the temporary movement joint between slab and wall. Product to be positioned at <insert centres>mm horizontal centres at <the centre line of the slab or XXXmm from the top of the slab>.

The dowel is to be locked in position after <insert time period> using the locking plate and resin supplied. System should be installed in accordance with Ancon's instructions and engineer's drawings.

Epoxy Resin

Each dowel is locked after a pre-determined time period (generally 3-4 weeks) with a high quality, two-part epoxy resin. The resin is mixed and poured into the L-shaped void former. Each dowel requires 1,500g of resin.

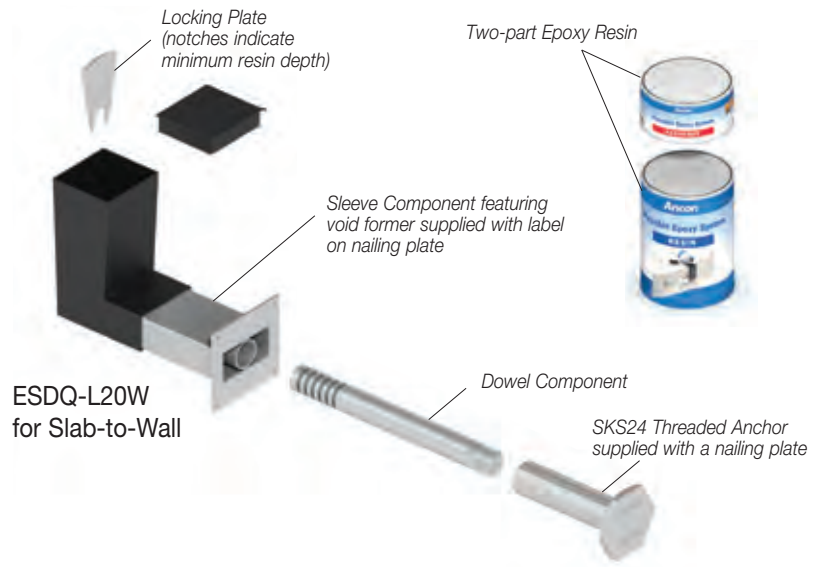

Void formers shown at Slab-to-Wall joint



Slab-to-Wall Application

Ancon Lockable Dowels

Performance Data

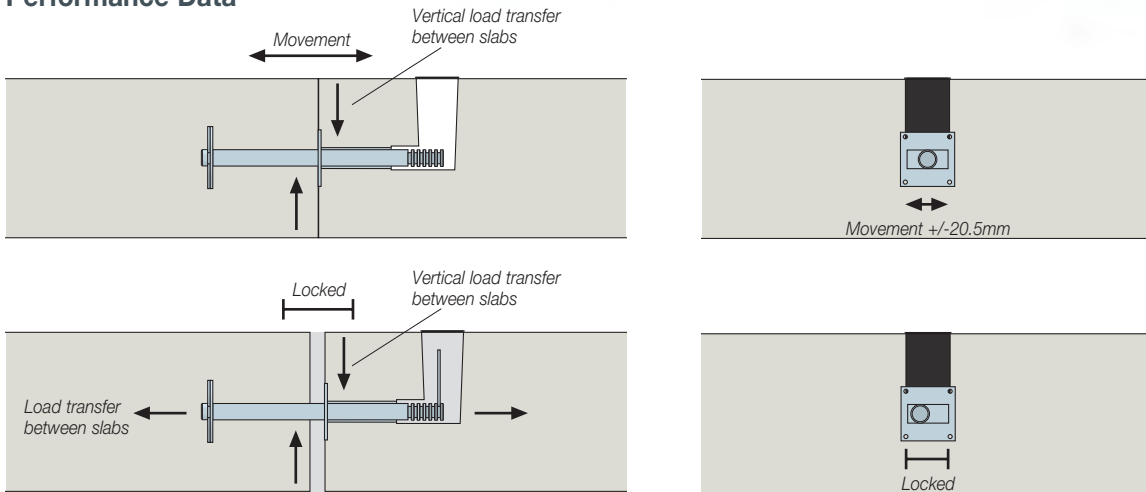

ESDQ-L20 Lockable Dowels (slab-to-slab)

Slab Thickness (mm)	Tension along line of dowel (kN)	Vertical Design Resistance (kN) for Various Design Joint Widths (mm) in C30/37 Concrete							
		5	10	15	20	25	30	35	40
160	45	12.0	12.0	12.0	12.0	12.0	12.0	12.0	12.0
180	65	25.0	25.0	25.0	25.0	25.0	25.0	25.0	25.0
200	80	40.0	40.0	40.0	40.0	40.0	40.0	40.0	40.0
220	100	53.6	53.6	53.6	53.6	53.6	53.6	53.6	52.7
240	100	62.2	62.2	62.2	62.2	60.6	57.8	55.2	52.7
260 and above	100	71.4	69.9	66.6	63.5	60.6	57.8	55.2	52.7

ESDQ-L20W Lockable Dowels (slab-to-wall)

Slab Thickness (mm)	Tension along line of dowel (kN)	Vertical Design Resistance (kN) for Various Design Joint Widths (mm) in C30/37 Concrete							
		5	10	15	20	25	30	35	40
160	45	12.0	12.0	12.0	12.0	12.0	12.0	12.0	12.0
180	65	25.0	25.0	25.0	25.0	25.0	25.0	25.0	25.0
200	80	40.0	40.0	40.0	40.0	40.0	40.0	40.0	40.0
220	80	53.6	53.6	53.6	53.6	53.6	53.6	53.6	52.7
240	80	62.2	62.2	62.2	62.2	60.6	57.8	55.2	52.7
260 and above	80	71.4	69.9	66.6	63.5	60.6	57.8	55.2	52.7

HLDQ-L30 Lockable Dowels (slab-to-slab)

Slab Thickness (mm)	Tension along line of dowel (kN)	Vertical Design Resistance (kN) for Various Design Joint Widths (mm) in C30/37 Concrete							
		5	10	15	20	25	30	35	40
240 and above	100	136.0	136.0	136.0	136.0	136.0	136.0	136.0	121.9

ESDQ-L20 Example

Slab thickness	= 240mm
Maximum width of joint	= 20mm
Concrete strength	= C30/37
Characteristic permanent action (dead load)	= 40kN/m $\gamma_G = 1.35^*$
Characteristic variable action (imposed load)	= 50kN/m $\gamma_Q = 1.5^*$
Design load	= $1.35 \times 40 + 1.5 \times 50 = 129\text{kN/m}$
Vertical design resistance	= 62.2kN (240mm slab 20mm joint)
Therefore centres for vertical load	= $62.2 / 129 = 0.482\text{m}$ use 450mm centres

Each dowel will in addition provide a design resistance across the joint of 100kN (for slab to wall this is 80kN), therefore the total design resistance in the direction of the dowel = $100 / 0.45 = 222\text{kN}$ (for slab to wall $80 / 0.45 = 177\text{kN}$).

If this is insufficient, the dowel centres can be reduced to a minimum of $1.5 \times$ slab thickness to increase the design resistance across the joint, in this example it would increase to $100 / 0.36 = 277\text{kN}$ (for slab to wall $80 / 0.36 = 222\text{kN}$).

**The partial safety factors of 1.35 (γ_G) and 1.5 (γ_Q) are those recommended in EN 1990 Eurocode: Basis for structural design. For designs to Eurocode 2, please refer to the national annex for the factors to be used in the country concerned. For designs to BS8110, $\gamma_G = 1.4$ and $\gamma_Q = 1.6$. Other national standards may require different safety factors.*

Note to above tables:

Increasing concrete grade will not improve the tensile performance of the dowel.

Joint Filler / Fire Protection

Ancon can provide information on a suitable joint filler and also recommend fire resistant material which could be used as part of an overall fire protection system.

Reinforcement Details

Local reinforcement is required around each Ancon Lockable Dowel to guarantee that the forces are transferred between the connectors and the concrete. See page 8 for full details.

Edge Distance and Spacings

For connectors working at or near their maximum capacity, the minimum spacing should be 1.5 times the slab thickness. Where the design load of the connector could be used in a thinner slab, a spacing of 1.5 times the thinner slab thickness can be used. The minimum end distance is always 0.5 times the spacing.

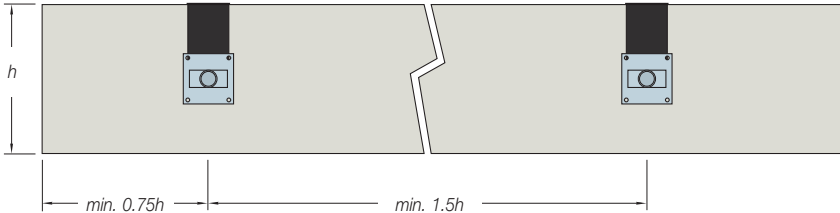

ESDQ-L20 Minimum Edge Distance and Spacings

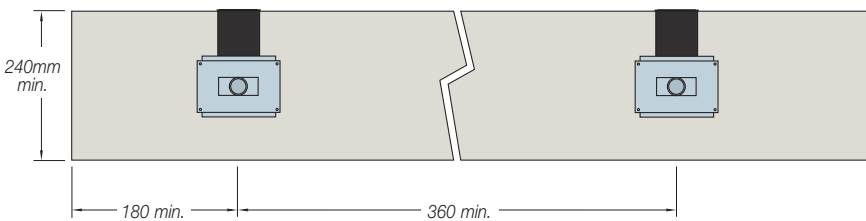

HLDQ-L30 Minimum Edge Distance and Spacings

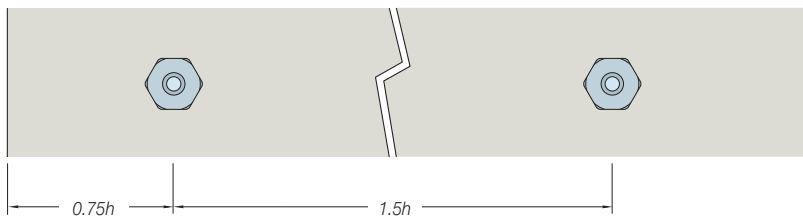

ESDQ-L20W Minimum Edge Distance and Spacings. h = depth of adjoining slab

ESDQ-L20 Example

Slab thickness	= 300mm
Maximum width of joint	= 20mm
Concrete strength	= C30/37
Design resistance/connector (based on slabs 260mm and above)	= 63.5kN
Spacing for max. load	$300 \times 1.5 = 450\text{mm}$
End distance for max. load	$450 \times 0.5 = 225\text{mm}$
Design resistance/metre	$= 63.5 / 0.45 = 141.1\text{kN/m}$

As an ESDQ-L20 can be used in a 220mm slab for a design resistance per connector of up to 53.6kN, the spacing can be based on a 220mm slab. Therefore:

Reduced spacing	$220 \times 1.5 = 330\text{mm}$
Reduced end distance	$330 \times 0.5 = 165\text{mm}$
Design resistance/metre	$53.6 / 0.33 = 162.4\text{kN/m}$

“ By using these dowels we have saved at least four weeks per storey. This construction method is just more efficient. Wet trades finish sooner on site and the anticipated movement at the joints was achieved without any issues. ”

Ben Ume, Director, Matthew Consultants
University Campus Suffolk phase 2, Ipswich, UK

“ The Lockable Dowel is a very clean system. If you have encountered pour strips before, the Lockable Dowel is a no-brainer. ”

Mahmoud Farawi, Skanska USA

Ancon Lockable Dowels

Reinforcement Details

Local reinforcement is required around each Ancon Lockable Dowel to guarantee that the forces are transferred between the connectors and the concrete. Correct detailing in accordance with appropriate design codes and the recommendations provided here will ensure the dowels attain their full capacity. The tables show the main reinforcement required, together with details of reinforcement above and below the connectors. Although only the sleeve components are illustrated, the same reinforcement is required around the dowel component.

Options for Main Reinforcement

Lockable Dowel Ref.	No. of U-bars each side		
	H12	H14	H16
ESDQ-L20	2	-	-
HLDQ-L30	4	3	3

Options for Longitudinal Reinforcement

Lockable Dowel Ref.	No. of bars top and bottom		
	H12	H14	H16
ESDQ-L20	2	-	-
HLDQ-L30	2	2	2



ESDQ-L20



HLDQ-L30

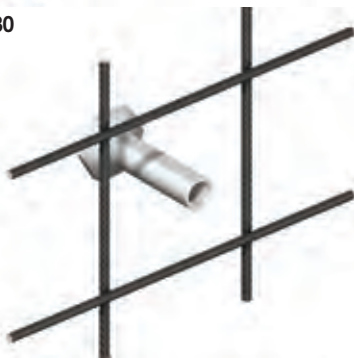

SKS24 Threaded Anchor, part of ESDQ-L20W

ESDQ-L20

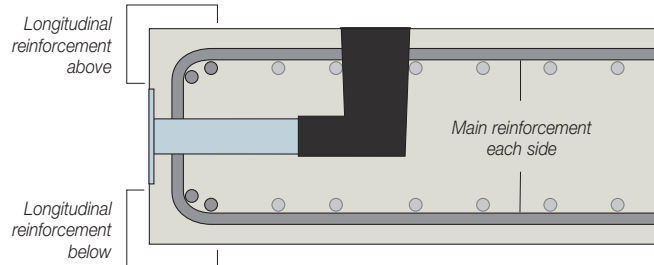
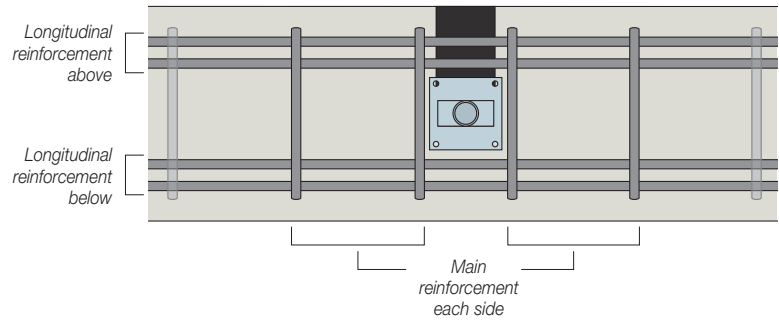

HLDQ-L30

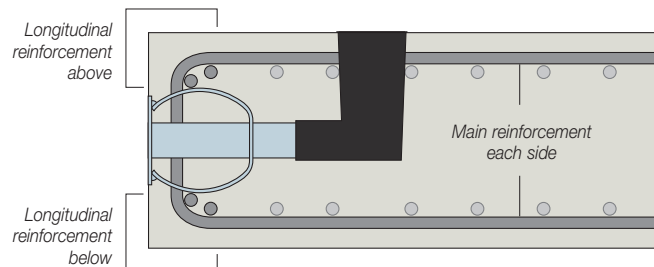
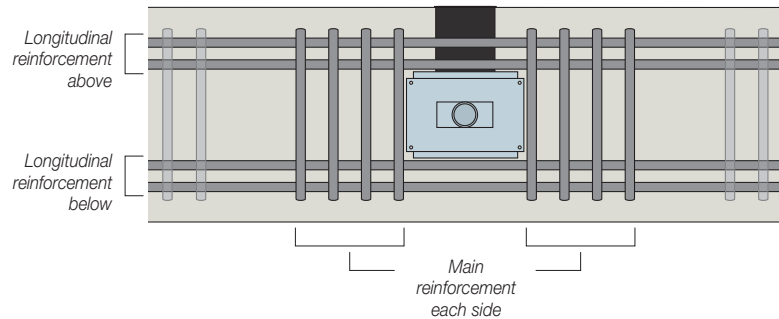

Threaded Anchor

Reinforcement around the Ancon Threaded Anchor should be a minimum diameter of 12mm, installed at maximum 200mm vertical and horizontal centres.

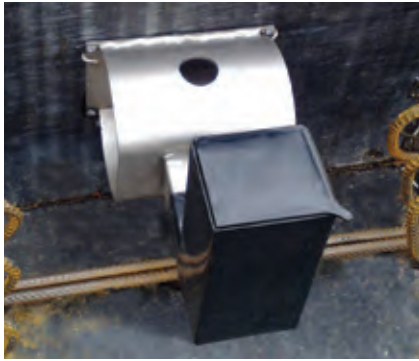

HLDQ-L30 Sleeve Component



“ PJ Carey chose the lockable dowel system because it offered time and cost savings, accelerating an already fast build programme. ”

Eamonn O'Donnell, Project Manager, PJ Carey (Contractors) Ltd
Emergency Care Centre, Aberdeen, UK

Dimensions

ESDQ-L20 Components Dowel Component

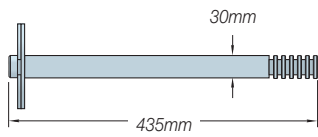

Sleeve Component

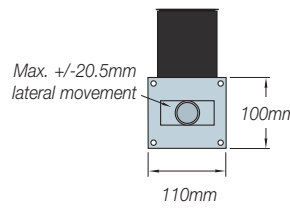
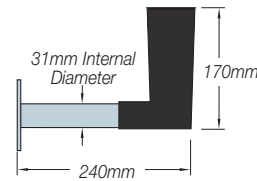

HLDQ-L30 Components Dowel Component

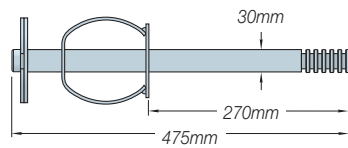
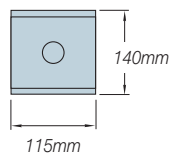

Sleeve Component

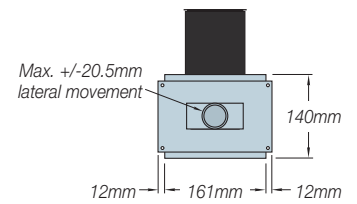
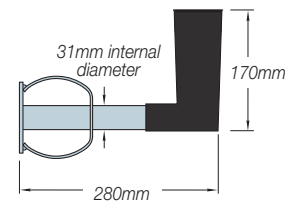

ESDQ-L20W Components SKS24 Threaded Anchor

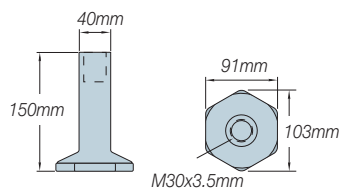

Dowel Component

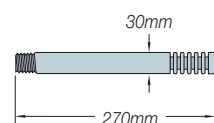

Sleeve Component

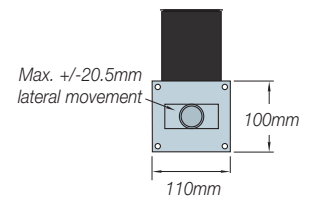
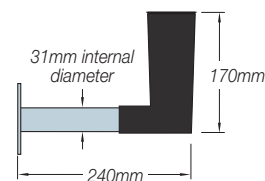

Ancon Lockable Dowels

Installation

Slab-to-Slab

Although installation is shown for the ESDQ-L20, the procedure is the same for the HLDQ-L30.

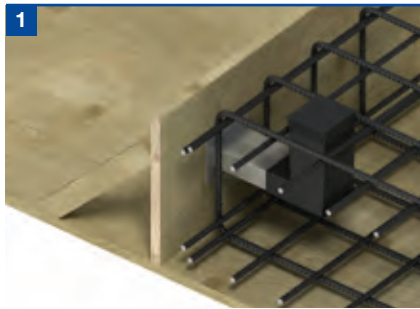

1 Nail the sleeve to the formwork either central in the slab or for slab depths over 300mm so the top of the void former is level with the top of the slab. Do not remove the label over the nailing plate as this prevents ingress of concrete into the sleeve. Fix the local reinforcement, as specified on engineer's drawings.



2 Pour the concrete, and when of sufficient strength, strike the formwork. Puncture the label to reveal the cylindrical sleeve only and insert the dowel until it is approximately 20mm from the back of the void former.



3 Fix the local reinforcement around the dowel component and pour the concrete.

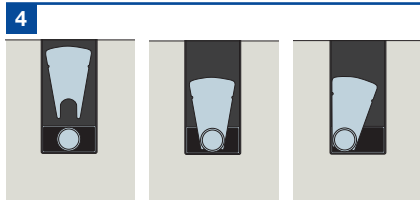

4 After a predetermined time period (generally 3-4 weeks), when movement between the slabs has stabilised and the joint between the slabs has been filled, the dowel is ready to be locked.

Fit the Locking Plate on a groove in the centre of the void former. The fan-shaped Locking Plate allows the dowel to be locked in any position.



5 Mix the two-part epoxy resin and pour into the void former. It is essential the resin flows along the stainless steel box section towards the joint and reaches the notches on the locking plate, which indicate minimum resin depth. Joint must be filled before resin is installed.



6 After 24 hours the void former can be filled with cementitious material, level with the top of the slab, to complete the installation.

The locked dowel continues to transfer vertical load between the slabs, but movement can no longer take place.

Slab-to-Wall



1 Nail the threaded anchor to the formwork so the dowel will be central in the adjoining slab or within 150mm of the top of slabs over 300mm. Fix the local reinforcement as specified on engineer's drawings and cast the concrete.

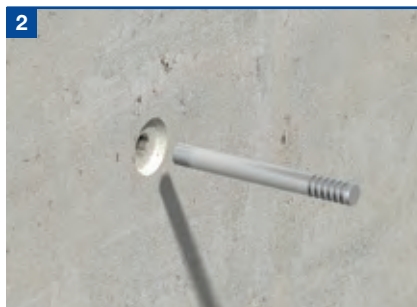

2 When concrete reaches sufficient strength, strike the formwork and remove nailing plate. Screw the dowel into the anchor.

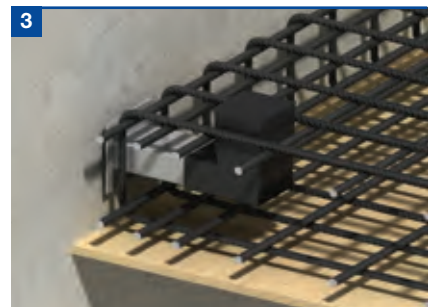

3 Puncture the label of the sleeve to reveal the cylindrical sleeve only. Push the sleeve over the dowel until it is flush with the concrete. Tie sleeve to reinforcement and pour concrete.

See Steps 4 to 6 above to complete installation.

Notes: Where deep concrete pours are proposed, the installation will require further consideration. More robust fixing of the sleeve and dowel components will be necessary, to avoid displacement during casting of the concrete.



Project References



200 Lockable dowels were installed on the James Hehir Building (University Campus Suffolk phase 2) in Ipswich, UK

'Highly Commended' in the 2010 CONSTRUCT award for innovation and best practice for its use of the Lockable Dowel.



5,000 Lockable dowels were installed on the Royal Children's Hospital in Melbourne, Australia



500 Lockable dowels were installed on the Emergency Care Centre in Aberdeen, UK

© RVMJM

© P J Carey (Contractors) Limited

Other Ancon Products

DSD/Q Shear Load Connectors

Ancon DSD and DSDQ double-dowel connectors are used to transfer shear across movement joints in suspended concrete slabs. They are more effective at transferring load and allowing movement than standard single dowels and can be used to eliminate double columns at structural movement joints in buildings. The Q version features a rectangular box section to allow lateral and some rotational movement.



Design Program Available

Plate Dowel Systems

Ancon MultiJoint is a plate dowel system for use in ground bearing concrete floor slabs. It is an all-in-one solution to load transfer, concrete contraction, armoured edge protection and formwork. Individual plate dowels are also available.



Punching Shear Reinforcement

Ancon Shearfix is used within a slab to provide additional reinforcement from punching shear around columns. The system consists of double-headed steel studs welded to flat rails and is designed to suit the load conditions and slab depth at each column using free calculation software from Ancon.



Design Program Available

Reinforcing Bar Couplers

The use of reinforcing bar couplers can provide significant advantages over lapped joints. Design and construction of the concrete can be simplified and the amount of reinforcement can be reduced. The Ancon range includes parallel-threaded, tapered-threaded and mechanically-bolted couplers.



Reinforcing Continuity Systems

Ancon Eazistrip is approved by UK CARES and consists of bent bars housed in a galvanised steel casing. Once installed, the protective cover is removed and the bars are straightened, ready for joining to the slab reinforcement. Alternatively, Ancon KSN Anchors are cast into the wall and, when the formwork and thread protection are removed, Bartec Plus threaded rebars are simply screwed into the anchors.



Insulated Balcony Connections

Ancon's thermally insulated connectors minimise heat loss at balcony locations while maintaining structural integrity. They provide a thermal break and, as a critical structural component, transfer moment, shear, tension and compression forces. Standard solutions are available for concrete-to-concrete, steel-to-concrete and steel-to-steel interfaces.



Masonry Support Systems
Lintels
Masonry Reinforcement
Windposts and Parapet Posts
Wall Ties and Restraint Fixings
Channel and Bolt Fixings
Tension and Compression Systems
Insulated Balcony Connectors

Shear Load Connectors

Punching Shear Reinforcement
Reinforcing Bar Couplers
Reinforcement Continuity Systems
Stainless Steel Fabrications
Flooring and Formed Sections
Refractory Fixings



Ancon®

Ancon Ltd
President Way, President Park
Sheffield S4 7UR
United Kingdom
Tel: +44 (0) 114 275 5224
Fax: +44 (0) 114 276 8543
Email: info@ancon.co.uk
Visit: www.ancon.co.uk

Ancon Building Products
98 Kurrajong Avenue
Mount Druitt
Sydney NSW 2770
Australia
Tel: +61 (0) 2 8808 3100
Fax: +61 (0) 2 9675 3390
Email: info@ancon.com.au
Visit: www.ancon.com.au

Ancon (Schweiz) AG
Grenzstrasse 24
3250 Lyss
Switzerland
Tel: +41 (0) 31 750 3030
Fax: +41 (0) 31 750 3033
Email: info@ancon.ch
Visit: www.ancon.ch

Ancon GmbH
Bartholomäusstrasse 26
90489 Nuremberg
Germany
Tel: +49 (0) 911 955 1234 0
Fax: +49 (0) 911 955 1234 9
Email: info@anconbp.de
Visit: www.anconbp.de

Ancon (Middle East) FZE
PO Box 17225
Jebel Ali
Dubai
United Arab Emirates
Tel: +971 (0) 4 883 4346
Fax: +971 (0) 4 883 4347
Email: info@ancon.ae
Visit: www.ancon.ae

Ancon Building Products
2/19 Nuttall Drive
Hillsborough
Christchurch 8022
New Zealand
Tel: +64 (0) 3 376 5205
Fax: +64 (0) 3 376 5206
Email: info@ancon.co.nz
Visit: www.ancon.co.nz

**Ancon Building Products
GesmbH**
Puchgasse 1
A-1220 Vienna
Austria
Tel: +43 (0) 1 259 58 62-0
Fax: +43 (0) 1 259 58 62-40
Email: info@ancon.at
Visit: www.ancon.at

These products are available from:

© Ancon

The construction applications and details provided in this literature are indicative only. In every case, project working details should be entrusted to appropriately qualified and experienced persons.

Whilst every care has been exercised in the preparation of this document to ensure that any advice, recommendations or information is accurate, no liability or responsibility of any kind is accepted in respect of Ancon.

With a policy of continuous product development Ancon reserves the right to modify product design and specification without due notice.

