

Concrete Trapezoidal Spacer with Holes & Notches

Description

A very strong fibre reinforced concrete trapezoidal shaped spacer with holes & notches available in a length of 220mm. Other lengths and covers can be produced supplied with or without holes or notches.

Bluebay Extruded Fibre Reinforced Concrete Spacers ensure that the specified concrete cover to the reinforcement for structures and structural elements is achieved, both before and during concreting. These spacers help to guarantee the durability of all structures. Spacers made of fibre concrete have an optimum material compatibility with in-situ concrete. Bluebay spacers are produced with strength and durability properties to match most site and precast concrete applications. The outstanding material properties of fibre reinforced concrete include:

Technical

- High compressive strength, accurate dimensional tolerances, no deformation with temperature fluctuations, excellent physical and chemical resistance
- Excellent bond with concrete, no hairline cracks between the spacer and concrete, suitable for impermeable concrete
- Fire resistant to the highest requirements specified
- in EN13501-1:2002 - Class 1A
- The performance of Bluebay spacers meets the requirements of BS 7973 (British Standard for Spacers) and of the Concrete Best Practice Guide produced by the European Concrete Societies Network.

Compression Strength	> 50 N/mm ²
BS7973	Satisfied
Water penetration	< 3 mm
Height/cover accuracy	+/- 1 mm on cover 25-75
Raw materials	CEM I 52.5 N
	Calcium carbonate
	PFA
	Concrete sand
Reinforcing	Polypropilene fibres
	Polyester threads
Slump	S1 0-3 cm

Length = 220mm, Cover = 45mm, Base = 45mm

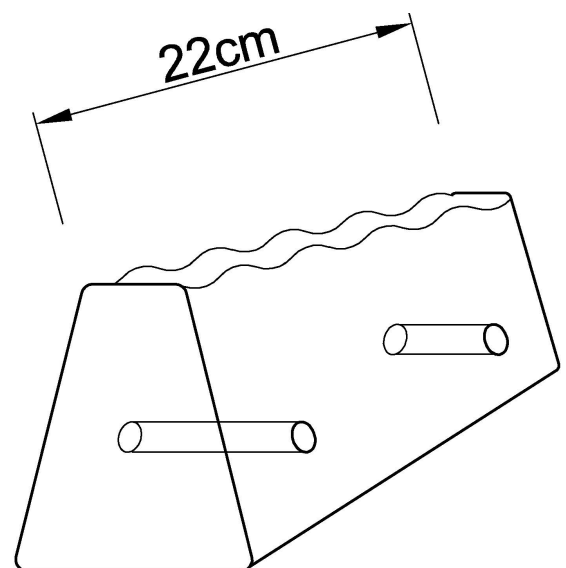

Note: In the absence of a specific harmonised European standard (hEN) or European Technical Approval (ETA), a CE Mark is not required.

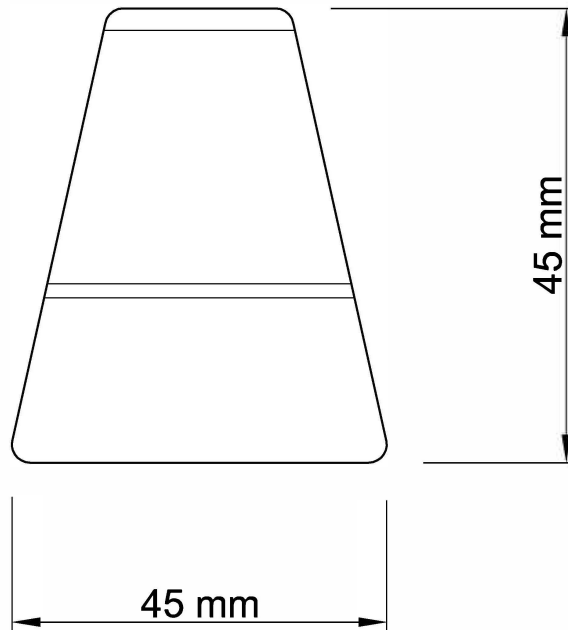
Concrete Trapezoidal Spacer with Holes Continued ..
Drawing Detail & Pack Sizes

Model-Code	Height/Cover (mm)	Base (mm)	Weight x piece (Kg)	Pcs x pallet	Weight per pallet (kg)
TPZN2245	45	45	0.8	1100	900

Other sizes are available on request